



S. W. PUTNAM.  
METAL-WORKING LATHES.

No. 192,129.

Patented June 19, 1877.

Fig. 2.

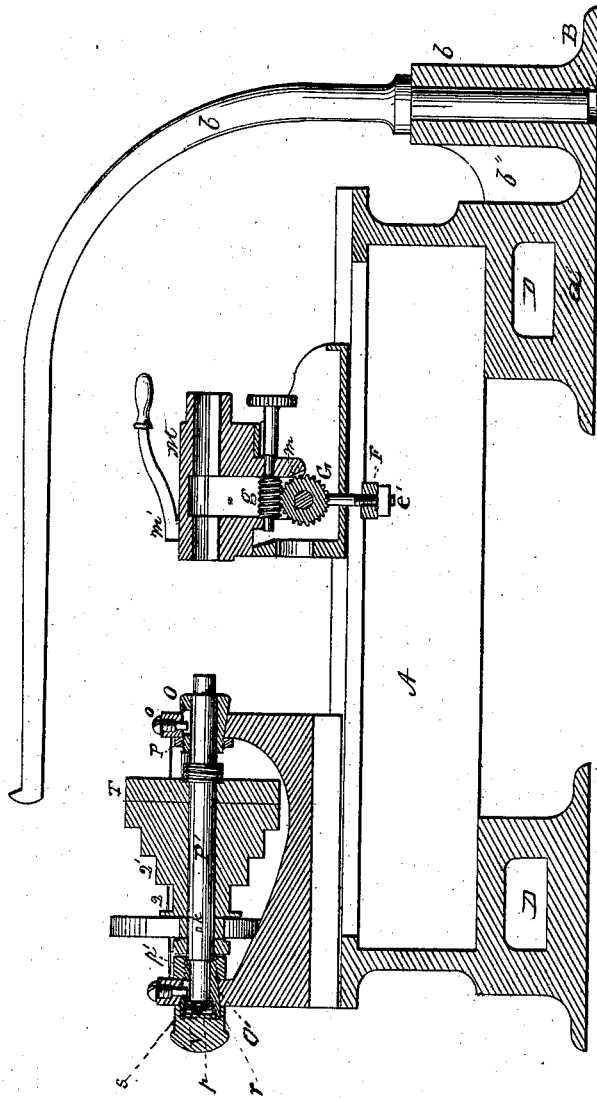

Witnesses:

C. Clarence Poole

Willis H. Maxon.

Inventor:

Sullivan W. Putnam  
per attys. A. H. Evans & Co.

S. W. PUTNAM.  
METAL-WORKING LATHES.

No. 192,129.

Patented June 19, 1877.

Fig. 3.

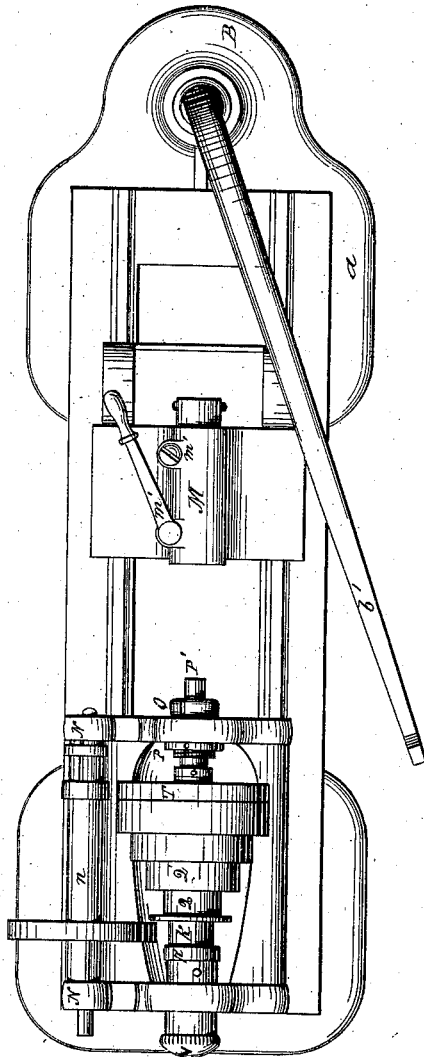

Witnesses:

Clarence Poole  
J. H. St. Maxon

Inventor:

Salmon W. Putnam  
per attys.  
A. H. Evans & Co.

S. W. PUTNAM.  
METAL-WORKING LATHES.

No. 192,129.

Patented June 19, 1877.

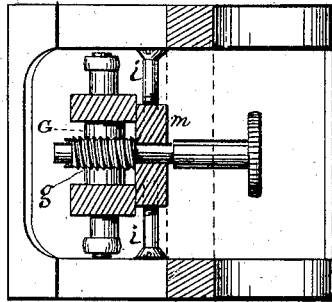

Fig. 4.

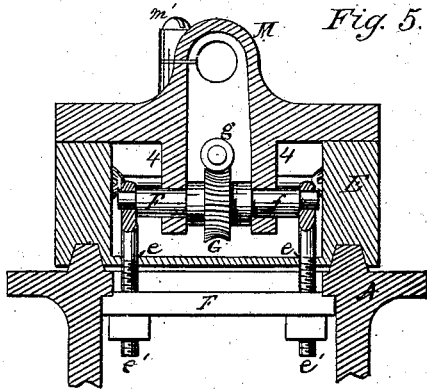

Fig. 5.

Fig. 6.



Witnesses.

C. Clarence Poole  
Willis H. Moxon

Inventor:

Salmon W. Putnam  
per attys.  
A. H. Evans & Co.

# UNITED STATES PATENT OFFICE.

SALMON W. PUTNAM, OF FITCHBURG, MASSACHUSETTS.

## IMPROVEMENT IN METAL-WORKING LATHES.

Specification forming part of Letters Patent No. **192,129**, dated June 19, 1877; application filed September 12, 1876.

*To all whom it may concern:*

Be it known that I, SALMON W. PUTNAM, of Fitchburg, Massachusetts, have invented certain new and useful Improvements in Metal-Working Lathes, of which the following is a full, clear, and exact description, reference being had to the accompanying drawings, making a part of this specification, in which—

Figure 1 is a perspective view of a lathe with my improvements attached. Fig. 2 is a longitudinal vertical view of the same through the line *x x* of Fig. 1. Fig. 3 is a plan view. Fig. 4 is a horizontal section through *y y* of Fig. 1. Fig. 5 is a cross-section through *z z* of Fig. 1. Fig. 6 is a front end view of the front box.

My invention relates more particularly to lathes for metal-working, although susceptible of being applied more or less to all turning or boring lathes; and it consists, first, in a device to prevent the pendulum-like swing of the tie-bolts and tie-piece when the bolts are loosened to move the tail-stock backward and forward on the lathe-bed; secondly, in a novel mode of securing the tail-stock to the bed-piece; thirdly, in a novel arrangement of the setting-over bolts to secure the spindle in any relative position to the central line, for the purpose of turning tapers; and, fourthly, in the construction and arrangement of the spindle bearings and boxes, as hereinafter described and claimed.

To enable others skilled in the art to make and use my invention, I will proceed to describe the exact manner in which I have carried out the several parts referred to.

In the drawings, A represents the lathe-bed, and *a a'* the base-pieces or legs, all of which are preferably cast in one piece. The leg *a'* is provided with the extension or foot *E*, from which rises the socket *b* for the reception of the crane *b'*. This socket is braced to the leg *a'* by the connecting-web *b''*. The legs are provided with the openings *D D*, and the lathe-bed with the openings *d d*, all extending entirely through the machine, for the reception of tools.

In the tail-stocks of lathes of this description the vertical tightening-bolts have had nothing to prevent lateral swing or play when the bolts are loosened to move forward or

backward the tail-stock on the lathe-bed. The result is that, on the gripe of the bolts being released and the tail-stock moved or suddenly stopped, the bolts and tie-piece are caused to swing like a pendulum and catch on the under side of the lathe-bed, to the great annoyance and inconvenience of the workman. To overcome this difficulty I place on the lower inside of the tail-stock *E* the guard holes or slots *e e*, as shown in Fig. 5. These guard-holes effectually prevent the swinging of the tie-bolts *e' e'*, and yet allow the "dead-spindle" to be set over the central line when desired.

To secure the tail-stock *E* to the bed-piece *A*, I combine the use of the tie-piece *F*, the tightening-bolts *e' e'*, the eccentric or crank shaft *f*, the gear *G*, and the worm-screw *g*. The upper part of the tail-stock is provided with the arms *4*, which furnish bearings for the eccentric shaft *f*, on which is rigidly secured the gear *G*, which is operated by the worm-screw *g*. On either end of the eccentric shaft is suspended the tie-bolts *e' e'* by means of an eye on the end of each bolt, which fits loosely over the ends of the eccentric shaft. To the lower ends of these bolts is secured the tie-piece *F* by means of nuts, as shown in Fig. 5.

It is evident from this description that, as the worm-screw *g* is turned, the gear *G* will be revolved, and with it the eccentric shaft *f*, by which means the tie-bolts *e' e'* will be raised and the tie-piece *F* be drawn tightly against the lathe-bed, thus securing the tail-stock in position, the eccentric shaft being effectually held at any point by the gear and the worm-screw, and thus avoiding any possibility of the tail stock working loose during the operation of turning or boring. To release the tail-stock from the bed-piece it is only necessary to reverse the direction of the worm-screw.

I am aware that tightening-bolts and eccentrics have been used for the purpose of securing the tail-stock to the lathe-bed; but, as heretofore constructed, they do not fully meet all the requirements, for the reason that it is essential to adjust the bolts so that the eccentric centers should be nearly on a line with the bolts when the gripe is complete; otherwise the eccentric has a tendency to work

loose. By my improvement, by adding the worm-gear much greater gripping-power is accumulated, and it becomes impossible to alter the position of the eccentric without the intent on the part of the workman, who must revolve the worm screw. In other words, by my improvement the eccentric will hold in any position.

The setting-over bolts in this description of lathes used to secure the spindle in any relative position to the central line for the purpose of turning tapers have heretofore extended through the sides of the tail-stock, and been operated from the outside. These bolts, thus constructed, are liable to be bent or broken, and are constantly in the way of the workman. To remedy this serious defect I have placed the setting-over bolts *i i* (see Fig. 4) inside of the tail-stock, and attached them by screw-points to the bearing *m* of the worm-screw *g*. Thus they are secured against accident, and entirely out of the way of the workmen.

The arms *N N*, which project from the side of the head-stock, furnish the bearings for the back gear shaft *n*.

I am not aware that any method has ever been devised to compensate for the wearage of the back-gear shaft and the shell on which the back-gears are attached. To accomplish this I make the ends of the shell tapering and slit them, so that they may be contracted by means of a ring. The same result may also be accomplished by splitting the shaft sufficiently to allow of its being expanded by a tapering screw.

I have ascertained from long experience that for the various purposes for which turning-lathes are used there is no better form of constructing the spindle bearings and boxes than having both of them (front and back bearings) straight, with shoulders at right angles to the central line of spindle to receive the lateral thrust and prevent end motion, provided compensation for wearage can be secured and the spindle be retained in its central and vertical line, which by my improvement I successfully accomplish.

My front box *O* is a tapering cylindrical tube, with a straight hole through its center for a bearing, and provided with an elongated slot or groove, into which a key or bolt end, *o*, (see Fig. 2,) is introduced, to prevent the box from turning in its socket, but yet allowing of longitudinal adjustment. This box is best constructed of one piece of metal and slotted to allow of compression, as shown in Fig. 6, when drawn into its tapering socket by nut *P*, thus keeping the front part of the spindle *P'* in a horizontal line regardless of its wearage or its vertical position.

My rear box *O'* is an improvement on patent issued to R. W. Drew, December 4, 1866, from which it differs in general construction by having one less number of pieces, and the great advantage of having the end thrust brought directly and only upon the step *p* and

nut *p'*, or upon box *O'*. In lathes heretofore constructed the end thrust has tended to throw the spindle not only against the step, but into or out of its front-box bearing.

The nut *p'* is made sufficiently large to receive the screw end of the box *O'* and allow ample space for said box to penetrate the ring without coming in contact with the gear *K*, which is immovably fixed upon the spindle *P'* by a key, *k*. The check-nuts *r s* are simply to keep the spindle in the same vertical line, or through gear *K* and against the nut *p'*, and have no action or co-operation whatever with the box *O*. In this respect my invention differs materially from lathes heretofore made, in which the check-nuts are used to draw the front spindle-bearing into an elliptical-shaped box, which is a serious objection, for it is evident as the front box or bearing wears the spindle has to be drawn along with it, and this movement would in a short time destroy the adjustment with back-gear'd lathes and render them useless, as the faces of the cogs on the gears *Q* and *T*, which run into those on the back shaft, would be thrown entirely out of line. The cap *V* serves the double purpose of a check-nut to step *p* and to box *O'*.

It is evident from the construction above described the spindle *P'* can be finished up, the gear *T* keyed and staked (upset) on, the cone *Q'* with the gear *Q* placed in position, and the gear *K* be securely keyed to the spindle; in fact, every part be properly fitted to the spindle before it is placed in position, and the boxes afterward adjusted. It is impossible to do this with lathes heretofore constructed, as the spindle has to be first passed through the front box and all the attachments subsequently put on, which can only be done in a very imperfect manner.

Having thus described my invention, what I claim as new, and desire to secure by Letters Patent, is—

1. In combination with the tail-stock of a lathe, the guards *e e* and tie-bolts *e' e'*, substantially as and for the purpose set forth.

2. In combination with the eccentric or crank shaft *f*, tie-piece *F*, and tie-bolts *e' e'*, the gear *G* and worm-screw *g*, substantially as and for the purpose described.

3. In combination with the bearing *m* of the slide *z*, the setting-over bolts *i i*, arranged within the tail-stock, substantially as and for the purpose set forth.

4. The combination, with the eccentric back-gear, of the slotted shell *n n''* and the ring *n'''*, as and for the purpose set forth.

5. The combination, with the live spindle of a turning-lathe provided with two straight journals, and with shoulders, as described, of the conical boxes *O* and *O'*, the cap *V*, and nuts *r* and *s*, as and for the purpose set forth.

SALMON W. PUTNAM.

Witnesses:  
GEO. E. PUTNAM,  
GEO. A. WILSON.